



PDM16 - POWER DISTRIBUTION MODULE



MoTeC's 16 output Power Distribution Module is designed to provide electronically switched power to the various electrical systems in the vehicle such as motors, lights, solenoids, and electronic devices such as ECUs and data acquisition systems.

The module replaces conventional relays, fuses and circuit breakers to simplify wiring and switch requirements, while increasing reliability.

► FEATURES

- Each output is over-current, short circuit and thermal overload protected.
- Outputs programmable in 1 A steps and controllable via a combination of switch inputs, CAN messages and logic functions.
- Performs up to 200 logic operations and functions that can be used to selectively turn off systems.
- Provides full diagnostic information via CAN.

► SPECIFICATIONS

For full details, see user manual at www.motec.com/downloads.

Inputs

- 12 x switch inputs: range 0 to 51 V, resolution 0.2 V

Outputs

- 8 x 20 A outputs: 20 A continuous, 115 A transient (typical)
- 8 x 8 A outputs: 8 A continuous, 60 A transient (typical)

Communications

- 1 x CAN

Operating Voltage

- 30 V max

Environmental Protection

- Rubber seal on lid and connectors, conformal coating on PCB

Physical

- 1 x 26, 1 x 8 and 1 x 1 pin Autosport connectors
- Case size 130 x 60 x 28 mm
- Weight 315 g

► COMPATIBILITY

MoTeC ECU Models

- M84, M400, M600, M800, M880, M1 Series (package dependant)

MoTeC Dash/Logger Models

- C125, C127, C185, C187, CDL3, SDL3, ADL3, ACL
- Discontinued: SDL, ADL2, ADL

► ACCESSORIES

MoTeC UTC #61059

⇒ UTC is required, not compatible with MoTeC CAN cable.

► SOFTWARE

Latest software can be found at www.motec.com/downloads.

PDM Manager software is used for:

- Configuring all inputs, outputs, CAN messages and conditions
- Monitoring all channel values
- Output testing
- Firmware updating.

► WIRING

→ The PDM is wired onto the CAN bus. Please ensure wiring is according to CAN requirements and the CAN bus has at least one 100R terminating resistor. More information can be found in the user manual at www.motec.com/downloads.

To communicate to the PC, a CAN connector must be wired into the CAN bus. To connect the PDM directly to the CAN connector, wire according to the following table.

PDM Pin	PDM Name	CAN Connector Pin	CAN Connector Wire
A_J	CAN Lo	4	Green
A_K	CAN Hi	5	White
A_G	0 V	1	Black

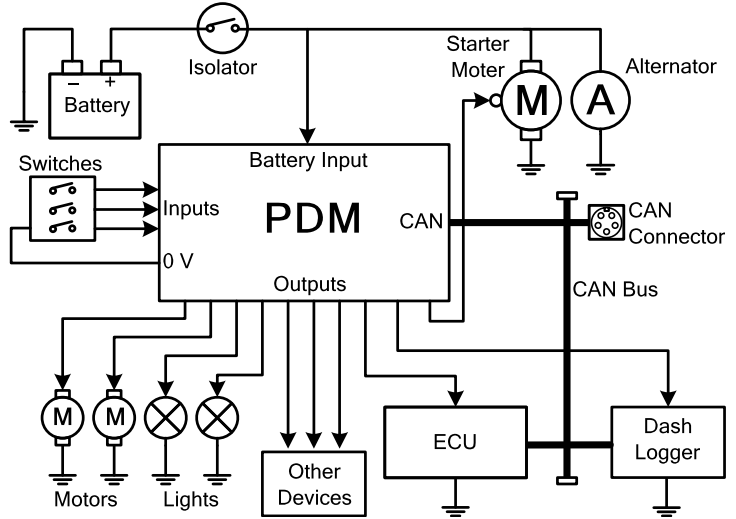

► DIMENSIONS AND MOUNTING

Measurements in mm.

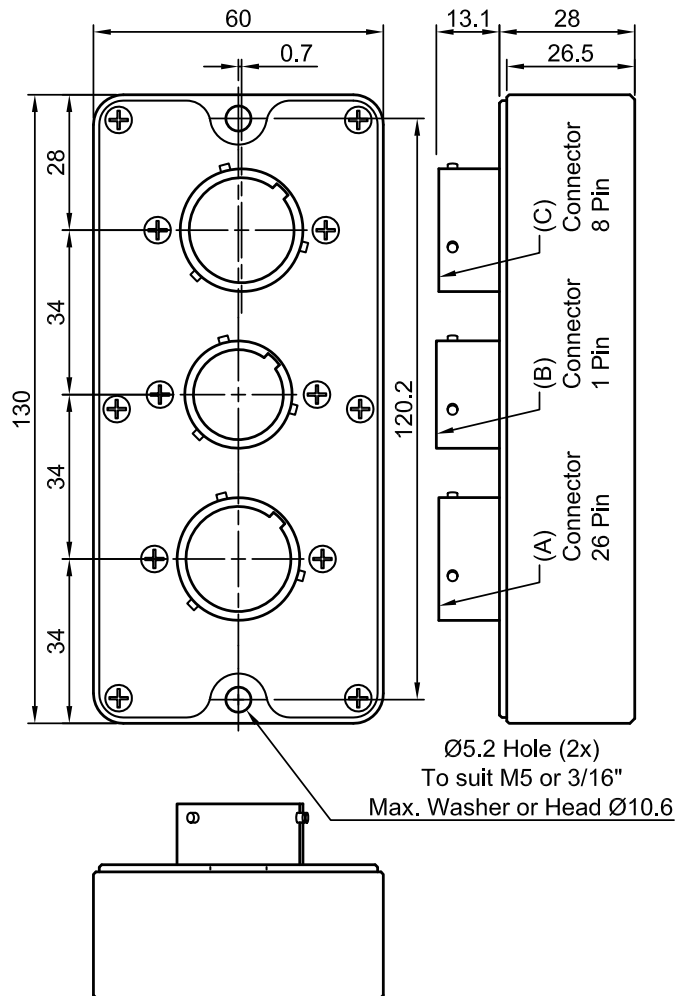

PINOUT

Connector A

26 pin autosport connector

Mating connector #65040

Pin	Function
A_A	8 A Output 9
A_B	8 A Output 10
A_C	8 A Output 11
A_D	Digital/Switch Input 1
A_E	Digital/Switch Input 2
A_F	Digital/Switch Input 3
A_G	0 V
A_H	0 V
A_J	CAN Low
A_K	CAN High
A_L	8 A Output 12
A_M	8 A Output 13
A_N	8 A Output 14
A_P	8 A Output 15
A_R	8 A Output 16
A_S	Digital/Switch Input 4
A_T	Digital/Switch Input 5
A_U	Digital/Switch Input 6
A_V	Digital/Switch Input 7
A_W	Digital/Switch Input 8
A_X	Digital/Switch Input 9
A_Y	Digital/Switch Input 10
A_Z	Digital/Switch Input 11
A_a	Digital/Switch Input 12
A_b	Batt –
A_c	Batt –

Connector B

1 pin waterproof connector

Mating connector:

#68093 (wire gauge #6 AWG)

#68094 (wire gauge #4 AWG)

Pin	Function
B_1	Batt +

Connector C

8 pin waterproof connector

Mating connector: #68092 (Deutsch AS616-08SN)

Pin	Function
C_A	20 A Output 1
C_B	20 A Output 2
C_C	20 A Output 3
C_D	20 A Output 4
C_E	20 A Output 5
C_F	20 A Output 6
C_G	20 A Output 7
C_H	20 A Output 8